

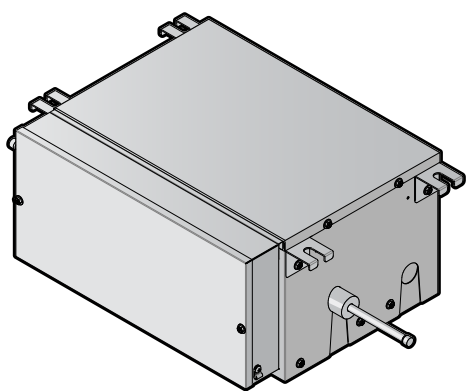

# Installation manual

## CO<sub>2</sub> Conveni-Pack: BEV2 unit



**BEV2N112ACV1B**

Installation manual  
CO<sub>2</sub> Conveni-Pack: BEV2 unit

**English**

EU – Svrhová deklaracija o skladnosti  
 EU – Sachverhalte Konformitätsklärung  
 UE – Déclaration de conformité de sécurité  
 EU – Conformitätsklärung und veiligheid

**Daikin Europe N.V.**

01 **Declaración de conformidad**  
 02 **Erklärung der Bestimmung**  
 03 **conformité de sécurité**  
 04 **Declarazione di conformità in materia di sicurezza**  
 05 **Декларация о соответствии по уровню безопасности**  
 06 **Declaración de conformidad relativa a seguridad**

**BEV2N112ACV1B,**

01 are in conformity with the provisions of the Regulation (EU) 2014/30/EU  
 02 following the provisions of:  
 03 **genetisk bestemmelse af**  
 04 **conformément aux dispositions de**  
 05 **võlgens de bepalingen van**  
 06 **siguendo las disposiciones de**  
 07 **secondo le disposizioni di**  
 08 **segundo as disposições de**  
 09 **в соответствии с положениями**  
 10 **under ägtslagets af**  
 11 **enligt bestämmelserna för**  
 12 **ihendhold til bestemmelserne i**  
 13 **noudiatien sääntöissä:**  
 14 **za dodizen ustanoveni:**  
 15 **prema odredbama:**  
 16 **követi alzi:**  
 17 **zgodne z postavitvenimi:**  
 18 **urmaßd prevedelne:**

**Machinery 2006/42/EC\*\***

**Electromagnetic Compatibility 2014/30/EU\***

01 **Note\***  
 02 **Hinweis\***  
 03 **Remarque\***  
 04 **Bemerk\***  
 05 **Note\***

06 **Note\***  
 07 **Information\***  
 08 **Merk\***  
 09 **Note\***  
 10 **Bemerk\***  
 11 **Information\***  
 12 **Merk\***  
 13 **Hinweis\***  
 14 **Posnámka\***  
 15 **Napomena\***

01\*\*  
 02\*\*  
 03\*\*  
 04\*\*  
 05\*\*

EU – Varnostna izjava o skladnosti  
 EU – Ohuusa vastavdeklaratsioon  
 EC – Декларация о соответствии с безопасностью  
 ES – Documento de declaración de seguridad  
 EU – Vyhlášení o zhode Bezpečnost  
 AB – Govenik uprnikluk bejani

**EU – Varnostna izjava o skladnosti**

17 **Erklärung der Bestimmung**  
 18 **conformité de sécurité**  
 19 **Declarazione di conformità in materia di sicurezza**  
 20 **Декларация о соответствии с безопасностью**  
 21 **Declaración de conformidad relativa a seguridad**

**BEV2N112ACV1B,**

01 are in conformity with the provisions of the Regulation (EU) 2014/30/EU  
 02 following the provisions of:  
 03 **genetisk bestemmelse af**  
 04 **conformément aux dispositions de**  
 05 **võlgens de bepalingen van**  
 06 **siguendo las disposiciones de**  
 07 **secondo le disposizioni di**  
 08 **segundo as disposições de**  
 09 **в соответствии с положениями**  
 10 **under ägtslagets af**  
 11 **enligt bestämmelserna för**  
 12 **ihendhold til bestemmelserne i**  
 13 **noudiatien sääntöissä:**  
 14 **za dodizen ustanoveni:**  
 15 **prema odredbama:**  
 16 **követi alzi:**  
 17 **zgodne z postavitvenimi:**  
 18 **urmaßd prevedelne:**

**Machinery 2006/42/EC\*\***

**Electromagnetic Compatibility 2014/30/EU\***

01 **Note\***  
 02 **Hinweis\***  
 03 **Remarque\***  
 04 **Bemerk\***  
 05 **Note\***

06 **Note\***  
 07 **Information\***  
 08 **Merk\***  
 09 **Note\***  
 10 **Bemerk\***  
 11 **Information\***  
 12 **Merk\***  
 13 **Hinweis\***  
 14 **Posnámka\***  
 15 **Napomena\***

01\*\*  
 02\*\*  
 03\*\*  
 04\*\*  
 05\*\*

EU – Izjava o skladnosti za sigurnost  
 EU – Võtsusaj megleidiseaj riialikoot  
 UE – Déclaration d'opinion sur la conformité de sécurité  
 UE – Declaratie de conformitate de siguranta

**EU – Izjava o skladnosti za sigurnost**

17 **Erklärung der Bestimmung**  
 18 **conformité de sécurité**  
 19 **Declarazione di conformità in materia di sicurezza**  
 20 **Декларация о соответствии с безопасностью**  
 21 **Declaración de conformidad relativa a seguridad**

**BEV2N112ACV1B,**

01 are in conformity with the provisions of the Regulation (EU) 2014/30/EU  
 02 following the provisions of:  
 03 **genetisk bestemmelse af**  
 04 **conformément aux dispositions de**  
 05 **võlgens de bepalingen van**  
 06 **siguendo las disposiciones de**  
 07 **secondo le disposizioni di**  
 08 **segundo as disposições de**  
 09 **в соответствии с положениями**  
 10 **under ägtslagets af**  
 11 **enligt bestämmelserna för**  
 12 **ihendhold til bestemmelserne i**  
 13 **noudiatien sääntöissä:**  
 14 **za dodizen ustanoveni:**  
 15 **prema odredbama:**  
 16 **követi alzi:**  
 17 **zgodne z postavitvenimi:**  
 18 **urmaßd prevedelne:**

**Machinery 2006/42/EC\*\***

**Electromagnetic Compatibility 2014/30/EU\***

01 **Note\***  
 02 **Hinweis\***  
 03 **Remarque\***  
 04 **Bemerk\***  
 05 **Note\***

06 **Note\***  
 07 **Information\***  
 08 **Merk\***  
 09 **Note\***  
 10 **Bemerk\***  
 11 **Information\***  
 12 **Merk\***  
 13 **Hinweis\***  
 14 **Posnámka\***  
 15 **Napomena\***

01\*\*  
 02\*\*  
 03\*\*  
 04\*\*  
 05\*\*

EU – Varnostna izjava o skladnosti  
 EU – Ohuusa vastavdeklaratsioon  
 EC – Декларация о соответствии с безопасностью  
 ES – Documento de declaración de seguridad  
 EU – Vyhlášení o zhode Bezpečnost  
 AB – Govenik uprnikluk bejani

**EU – Varnostna izjava o skladnosti**

17 **Erklärung der Bestimmung**  
 18 **conformité de sécurité**  
 19 **Declarazione di conformità in materia di sicurezza**  
 20 **Декларация о соответствии с безопасностью**  
 21 **Declaración de conformidad relativa a seguridad**

**BEV2N112ACV1B,**

01 are in conformity with the provisions of the Regulation (EU) 2014/30/EU  
 02 following the provisions of:  
 03 **genetisk bestemmelse af**  
 04 **conformément aux dispositions de**  
 05 **võlgens de bepalingen van**  
 06 **siguendo las disposiciones de**  
 07 **secondo le disposizioni di**  
 08 **segundo as disposições de**  
 09 **в соответствии с положениями**  
 10 **under ägtslagets af**  
 11 **enligt bestämmelserna för**  
 12 **ihendhold til bestemmelserne i**  
 13 **noudiatien sääntöissä:**  
 14 **za dodizen ustanoveni:**  
 15 **prema odredbama:**  
 16 **követi alzi:**  
 17 **zgodne z postavitvenimi:**  
 18 **urmaßd prevedelne:**

**Machinery 2006/42/EC\*\***

**Electromagnetic Compatibility 2014/30/EU\***

01 **Note\***  
 02 **Hinweis\***  
 03 **Remarque\***  
 04 **Bemerk\***  
 05 **Note\***

06 **Note\***  
 07 **Information\***  
 08 **Merk\***  
 09 **Note\***  
 10 **Bemerk\***  
 11 **Information\***  
 12 **Merk\***  
 13 **Hinweis\***  
 14 **Posnámka\***  
 15 **Napomena\***

01\*\*  
 02\*\*  
 03\*\*  
 04\*\*  
 05\*\*

EU – Izjava o skladnosti za sigurnost  
 EU – Võtsusaj megleidiseaj riialikoot  
 UE – Déclaration d'opinion sur la conformité de sécurité  
 UE – Declaratie de conformitate de siguranta

**EU – Izjava o skladnosti za sigurnost**

17 **Erklärung der Bestimmung**  
 18 **conformité de sécurité**  
 19 **Declarazione di conformità in materia di sicurezza**  
 20 **Декларация о соответствии с безопасностью**  
 21 **Declaración de conformidad relativa a seguridad**

**BEV2N112ACV1B,**

01 are in conformity with the provisions of the Regulation (EU) 2014/30/EU  
 02 following the provisions of:  
 03 **genetisk bestemmelse af**  
 04 **conformément aux dispositions de**  
 05 **võlgens de bepalingen van**  
 06 **siguendo las disposiciones de**  
 07 **secondo le disposizioni di**  
 08 **segundo as disposições de**  
 09 **в соответствии с положениями**  
 10 **under ägtslagets af**  
 11 **enligt bestämmelserna för**  
 12 **ihendhold til bestemmelserne i**  
 13 **noudiatien sääntöissä:**  
 14 **za dodizen ustanoveni:**  
 15 **prema odredbama:**  
 16 **követi alzi:**  
 17 **zgodne z postavitvenimi:**  
 18 **urmaßd prevedelne:**

**Machinery 2006/42/EC\*\***

**Electromagnetic Compatibility 2014/30/EU\***

01 **Note\***  
 02 **Hinweis\***  
 03 **Remarque\***  
 04 **Bemerk\***  
 05 **Note\***

06 **Note\***  
 07 **Information\***  
 08 **Merk\***  
 09 **Note\***  
 10 **Bemerk\***  
 11 **Information\***  
 12 **Merk\***  
 13 **Hinweis\***  
 14 **Posnámka\***  
 15 **Napomena\***

01\*\*  
 02\*\*  
 03\*\*  
 04\*\*  
 05\*\*

EU – Varnostna izjava o skladnosti  
 EU – Ohuusa vastavdeklaratsioon  
 EC – Декларация о соответствии с безопасностью  
 ES – Documento de declaración de seguridad  
 EU – Vyhlášení o zhode Bezpečnost  
 AB – Govenik uprnikluk bejani

**EU – Varnostna izjava o skladnosti**

17 **Erklärung der Bestimmung**  
 18 **conformité de sécurité**  
 19 **Declarazione di conformità in materia di sicurezza**  
 20 **Декларация о соответствии с безопасностью**  
 21 **Declaración de conformidad relativa a seguridad**

**BEV2N112ACV1B,**

01 are in conformity with the provisions of the Regulation (EU) 2014/30/EU  
 02 following the provisions of:  
 03 **genetisk bestemmelse af**  
 04 **conformément aux dispositions de**  
 05 **võlgens de bepalingen van**  
 06 **siguendo las disposiciones de**  
 07 **secondo le disposizioni di**  
 08 **segundo as disposições de**  
 09 **в соответствии с положениями**  
 10 **under ägtslagets af**  
 11 **enligt bestämmelserna för**  
 12 **ihendhold til bestemmelserne i**  
 13 **noudiatien sääntöissä:**  
 14 **za dodizen ustanoveni:**  
 15 **prema odredbama:**  
 16 **követi alzi:**  
 17 **zgodne z postavitvenimi:**  
 18 **urmaßd prevedelne:**

**Machinery 2006/42/EC\*\***

**Electromagnetic Compatibility 2014/30/EU\***

01 **Note\***  
 02 **Hinweis\***  
 03 **Remarque\***  
 04 **Bemerk\***  
 05 **Note\***

06 **Note\***  
 07 **Information\***  
 08 **Merk\***  
 09 **Note\***  
 10 **Bemerk\***  
 11 **Information\***  
 12 **Merk\***  
 13 **Hinweis\***  
 14 **Posnámka\***  
 15 **Napomena\***

01\*\*  
 02\*\*  
 03\*\*  
 04\*\*  
 05\*\*

EU – Varnostna izjava o skladnosti  
 EU – Ohuusa vastavdeklaratsioon  
 EC – Декларация о соответствии с безопасностью  
 ES – Documento de declaración de seguridad  
 EU – Vyhlášení o zhode Bezpečnost  
 AB – Govenik uprnikluk bejani

**EU – Varnostna izjava o skladnosti**

17 **Erklärung der Bestimmung**  
 18 **conformité de sécurité**  
 19 **Declarazione di conformità in materia di sicurezza**  
 20 **Декларация о соответствии с безопасностью**  
 21 **Declaración de conformidad relativa a seguridad**

**BEV2N112ACV1B,**

01 are in conformity with the provisions of the Regulation (EU) 2014/30/EU  
 02 following the provisions of:  
 03 **genetisk bestemmelse af**  
 04 **conformément aux dispositions de**  
 05 **võlgens de bepalingen van**  
 06 **siguendo las disposiciones de**  
 07 **secondo le disposizioni di**  
 08 **segundo as disposições de**  
 09 **в соответствии с положениями**  
 10 **under ägtslagets af**  
 11 **enligt bestämmelserna för**  
 12 **ihendhold til bestemmelserne i**  
 13 **noudiatien sääntöissä:**  
 14 **za dodizen ustanoveni:**  
 15 **prema odredbama:**  
 16 **követi alzi:**  
 17 **zgodne z postavitvenimi:**  
 18 **urmaßd prevedelne:**

**Machinery 2006/42/EC\*\***

**Electromagnetic Compatibility 2014/30/EU\***

01 **Note\***  
 02 **Hinweis\***  
 03 **Remarque\***  
 04 **Bemerk\***  
 05 **Note\***

06 **Note\***  
 07 **Information\***  
 08 **Merk\***  
 09 **Note\***  
 10 **Bemerk\***  
 11 **Information\***  
 12 **Merk\***  
 13 **Hinweis\***  
 14 **Posnámka\***  
 15 **Napomena\***

01\*\*  
 02\*\*  
 03\*\*  
 04\*\*  
 05\*\*



**UKCA – Safety declaration of conformity**

**Daikin Europe N.V.**

declares under its sole responsibility that the products to which this declaration relates:

**BEV2N112ACV1B,**

are in conformity with the following directive(s) or regulation(s), provided that the products are used in accordance with our instructions:

S.I. 2008/1597: Supply of Machinery (Safety) Regulations 2008\*\*  
S.I. 2016/1091: Electromagnetic Compatibility Regulations 2016\*

as amended,

following the provisions of: BS EN 60335-2-40,

\* as set out in <A> and judged positively by <B> according to the **Certificate <C>**.

\*\* Daikin Europe N.V. is authorised to compile the Technical Construction File.

<A>	DAIKIN.TCF.035A4/03-2024
<B>	—
<C>	—



## Table of contents

<b>1</b>	<b>About the documentation</b>	<b>4</b>
1.1	About this document.....	4
<b>2</b>	<b>Specific installer safety instructions</b>	<b>4</b>
<b>3</b>	<b>About the box</b>	<b>5</b>
3.1	To remove the accessories .....	6
<b>4</b>	<b>About the unit</b>	<b>6</b>
<b>5</b>	<b>Unit installation</b>	<b>6</b>
5.1	Preparing the installation site .....	6
5.1.1	Installation site requirements of the unit .....	6
5.1.2	Additional installation site requirements for CO <sub>2</sub> refrigerant.....	7
5.2	Mounting the unit.....	7
5.2.1	Guidelines when installing the unit.....	7
5.2.2	To mount the unit.....	7
<b>6</b>	<b>Piping installation</b>	<b>8</b>
6.1	Preparing refrigerant piping.....	8
6.1.1	Refrigerant piping requirements.....	8
6.1.2	Refrigerant piping insulation .....	8
6.2	Connecting the refrigerant piping .....	8
6.2.1	To connect the refrigerant piping to the indoor unit ....	8
<b>7</b>	<b>Electrical installation</b>	<b>9</b>
7.1	To connect the electrical wiring to the BEV2 unit.....	9
<b>8</b>	<b>Commissioning</b>	<b>10</b>
8.1	Checklist before commissioning.....	10
<b>9</b>	<b>Disposal</b>	<b>10</b>
<b>10</b>	<b>Technical data</b>	<b>10</b>
10.1	Wiring diagram .....	11
10.1.1	Unified wiring diagram legend.....	11

# 1 About the documentation

## 1.1 About this document

### WARNING

Make sure installation, servicing, maintenance, repair and applied materials follow the instructions from Daikin (including all documents listed in "Documentation set") and, in addition, comply with applicable legislation and are performed by qualified persons only. In Europe and areas where IEC standards apply, EN/IEC 60335-2-40 is the applicable standard.

#### Target audience

Authorised installers

### INFORMATION

This appliance is intended to be used by expert or trained users in shops, in light industry and on farms, or for commercial use by lay persons.

#### Documentation set

This document is part of a documentation set. The complete set consists of:

- **General safety precautions:**

- Safety instructions that you must read before installing
- Format: Paper (in the box of the **indoor unit**)

- **Installation manual:**

- Installation instructions
- Format: Paper (supplied in the kit)

- **Installer reference guide:**

- Preparation of the installation, good practices, reference data, ...
- Format: Digital files on <https://www.daikin.eu>. Use the search function  to find your model.

The latest revision of the supplied documentation is published on the regional Daikin website and is available via your dealer.

Scan the QR code below to find the full documentation set and more information about your product on Daikin website.



The original instructions are written in English. All other languages are translations of the original instructions.

#### Technical engineering data

- A **subset** of the latest technical data is available on the regional Daikin website (publicly accessible).
- The **full set** of the latest technical data is available on the Daikin Business Portal (authentication required).

## 2 Specific installer safety instructions

Always observe the following safety instructions and regulations.

#### Unit installation (see "5 Unit installation" [▶ 6])

### WARNING

- Installation shall be done by an installer, the choice of materials and installation shall comply with the applicable legislation. In Europe, EN378 is the applicable standard.
- Make sure to install all necessary countermeasures in case of refrigerant leakage according to standard EN378 (see "5.1.2 Additional installation site requirements for CO<sub>2</sub> refrigerant" [▶ 7]).
- Make sure to install a CO<sub>2</sub> leak detector (field supply) in every room with refrigerant piping, air conditioning units, showcases or blower coils, and enable the function for refrigerant leak detection (see the installation manual of the indoor units).

### WARNING

Make sure installation, servicing, maintenance, repair and applied materials follow the instructions from Daikin (including all documents listed in "Documentation set") and, in addition, comply with applicable legislation and are performed by qualified persons only. In Europe and areas where IEC standards apply, EN/IEC 60335-2-40 is the applicable standard.

### CAUTION

Appliance NOT accessible to the general public, install it in a secured area, protected from easy access.

This unit, both indoor and outdoor, is suitable for installation in a commercial and light industrial environment.



**CAUTION**

This equipment is NOT intended for use in residential locations and will NOT guarantee to provide adequate protection to radio reception in such locations.

**Refrigerant piping installation (see "6 Piping installation" [▶ 8])**



**CAUTION**

Install the refrigerant piping or components in a position where they are unlikely to be exposed to any substance which may corrode components containing refrigerant, unless the components are constructed of materials that are inherently resistant to corrosion or are suitably protected against corrosion.



**WARNING**

- Use K65 piping for high-pressure applications with a working gauge pressure of 120 bar or 90 bar, depending on its location in the system.
- Use K65 unions and fittings approved for a working gauge pressure of 120 bar or 90 bar, depending on its location in the system.
- ONLY brazing is allowed for connection of pipes. No other types of connections are allowed.
- Expanding of pipes is NOT allowed.



**CAUTION**

NEVER bend high pressure piping! Bending can reduce the pipe thickness and thus weaken the piping. ALWAYS use K65 fittings.

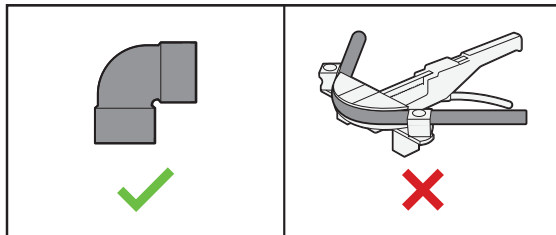

**Electrical installation (see "7 Electrical installation" [▶ 9])**



**WARNING**

ALWAYS use multicore cable for power supply cables.



**WARNING**

- All wiring MUST be performed by an authorised electrician and MUST comply with the national wiring regulation.
- Make electrical connections to the fixed wiring.
- All components procured on-site and all electrical construction MUST comply with the applicable legislation.



**WARNING**

- If the power supply has a missing or wrong N-phase, equipment might break down.
- Establish proper earthing. Do NOT earth the unit to a utility pipe, surge absorber, or telephone earth. Incomplete earthing may cause electrical shocks.
- Install the required fuses or circuit breakers.
- Secure the electrical wiring with cable ties so that the cables do NOT come into contact with sharp edges or piping, particularly on the high-pressure side.
- Use the included cables (in the box of the indoor unit) and make sure that there is no strain on the terminal connections or wires. Improper connections or improper securing of wires can cause overheating, electrical shocks or fire.
- Do NOT use taped wires, extension cords, or connections from a star system. They can cause overheating, electrical shocks or fire.



**WARNING**

Use an all-pole disconnection type breaker with at least 3 mm between the contact point gaps that provides full disconnection under overvoltage category III.



**WARNING**

If the supply cord is damaged, it MUST be replaced by the manufacturer, its service agent or similarly qualified persons in order to avoid a hazard.



**WARNING**

Keep the interconnection wiring away from copper pipes without thermal insulation as such pipes will be very hot.

Following symbols may occur on the indoor unit:

Symbol	Explanation
	Measure the voltage at the terminals of main circuit capacitors or electrical components before servicing.

**Commissioning (see "8 Commissioning" [▶ 10])**



**WARNING**

Make sure that the service cover is closed after completing the installation of the indoor unit, BEV2 unit, and outdoor unit.

### 3 About the box



**NOTICE**

Before installation, check the packaging and parts for damage. Make sure that the shipment is complete.

Keep the following in mind:

- At delivery, the unit MUST be checked for damage and completeness. Any damage or missing parts MUST be reported immediately to the claims agent of the carrier.
- Bring the packed unit as close as possible to its final installation position to prevent damage during transport.
- Prepare in advance the path along which you want to bring the unit to its final installation position.

## 4 About the unit

### 3.1 To remove the accessories

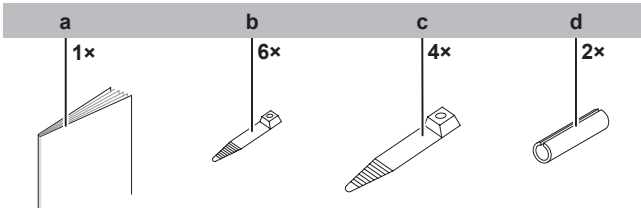

- a BEV unit installation manual
- b Tie wrap (short)
- c Tie wrap (long)
- d Insulation for fitting

## 4 About the unit



### INFORMATION

The BEV2 unit is an extension for the indoor unit containing external expansion valves. It is mandatory for some units using CO<sub>2</sub> refrigerant; see the Daikin catalogue for combinations.

## 5 Unit installation



### WARNING

- Installation shall be done by an installer, the choice of materials and installation shall comply with the applicable legislation. In Europe, EN378 is the applicable standard.
- Make sure to install all necessary countermeasures in case of refrigerant leakage according to standard EN378 (see "[5.1.2 Additional installation site requirements for CO<sub>2</sub> refrigerant](#)" [▶ 7]).
- Make sure to install a CO<sub>2</sub> leak detector (field supply) in every room with refrigerant piping, air conditioning units, showcases or blower coils, and enable the function for refrigerant leak detection (see the installation manual of the indoor units).

### 5.1 Preparing the installation site

Avoid installation in an environment with a lot of organic solvents such as ink and siloxane.

#### 5.1.1 Installation site requirements of the unit



### INFORMATION

The sound pressure level is less than 70 dBA.



### INFORMATION

Equipment meets the requirement for commercial and light-industrial location when professionally installed and maintained.



### CAUTION

This equipment is NOT intended for use in residential locations and will NOT guarantee to provide adequate protection to radio reception in such locations.



### CAUTION

Appliance NOT accessible to the general public, install it in a secured area, protected from easy access.

This unit, both indoor and outdoor, is suitable for installation in a commercial and light industrial environment.



### NOTICE

- The professional installer shall evaluate the EMC situation before installation, if the equipment is installed closer than 30 m to a residential location.
- Special installation measures are NOT required to minimize EMC (electro-magnetic) emissions.



### NOTICE

This is a class A product. In a domestic environment this product may cause radio interference in which case the user may be required to take adequate measures.

- **Ceiling insulation.** When conditions in the ceiling exceed 30°C and a relative humidity of 80%, or when fresh air is inducted into the ceiling, then additional insulation is required (minimum 10 mm thickness, polyethylene foam).
- **Ceiling strength.** Check whether the ceiling is strong enough to support the weight of the unit. If there is a risk, reinforce the ceiling before installing the unit.
  - For existing ceilings, use anchors.
  - For new ceilings, use sunken inserts, sunken anchors or other field supplied parts.
- **Spacing.** Mind the following requirements:

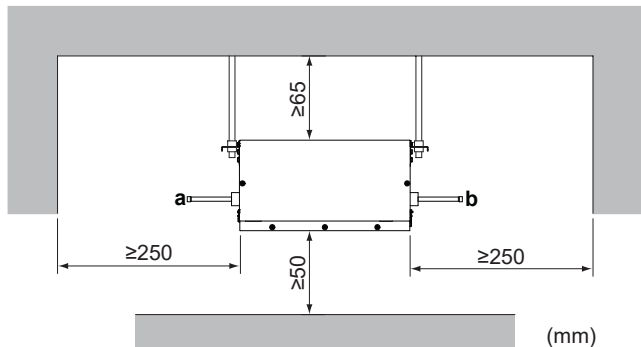

- a Outdoor unit side
- b Indoor units side

- **Service space.** Be sure to install the inspection door at the control box side.

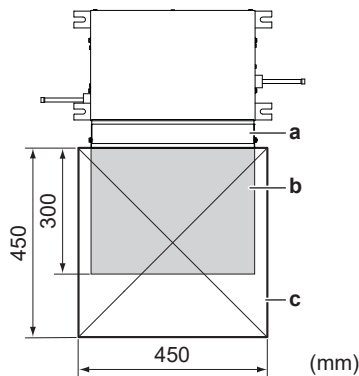

- a Control box
- b Service space
- c Inspection door

## **i** INFORMATION

- The maximum installation distance between the indoor unit and the BEV2 unit depends on the length of the included transmission and power supply cables.
- Make sure to install the units so the cables reach both units terminals.
- The maximum installation height difference between the indoor unit and the BEV2 unit is  $\leq 0.5$  m.

### 5.1.2 Additional installation site requirements for CO<sub>2</sub> refrigerant

## **i** INFORMATION

For units using R744 refrigerant, additional installation site requirements apply. For more information, see the reference guide or installation manual of the indoor unit.

## 5.2 Mounting the unit

### 5.2.1 Guidelines when installing the unit

- **Orientation of the unit.** Install the unit according to labels on the sides of the unit "TO ODU" (facing the outdoor unit) and "TO IDU" (facing the indoor unit).

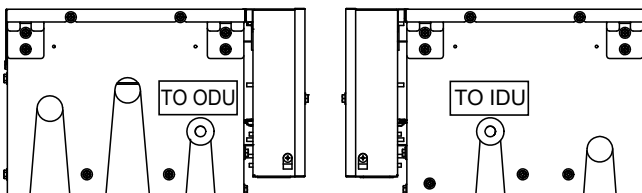

**TO ODU** Install this side facing to outdoor unit  
**TO IDU** Install this side facing to indoor unit

- **Suspension bolts and unit.** Use M8~M10 suspension bolts for installation. Attach the hanger bracket to the suspension bolt. Fix it securely using a nut and washer on the top and bottom of the hanger bracket.

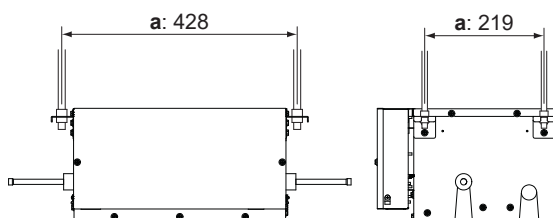

a Suspension bolt pitch

- **Hanger bracket.** Make sure to support the connection piping around the unit using hanger brackets installed within 1 meter of the side of the unit. Avoid putting excessive weight on the hanger bracket; otherwise the unit may fall and cause injuries.

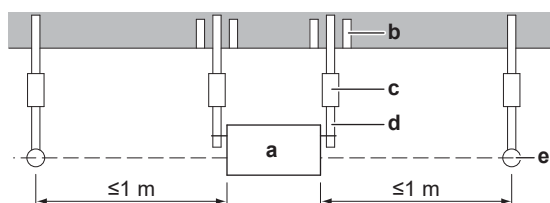

a Unit  
 b Anchor  
 c Long nut or turnbuckle  
 d Suspension bolt  
 e Hanger bracket

### 5.2.2 To mount the unit

#### Changing the installation position of the control box

**Prerequisite:** The position of the control box can be changed if necessary.

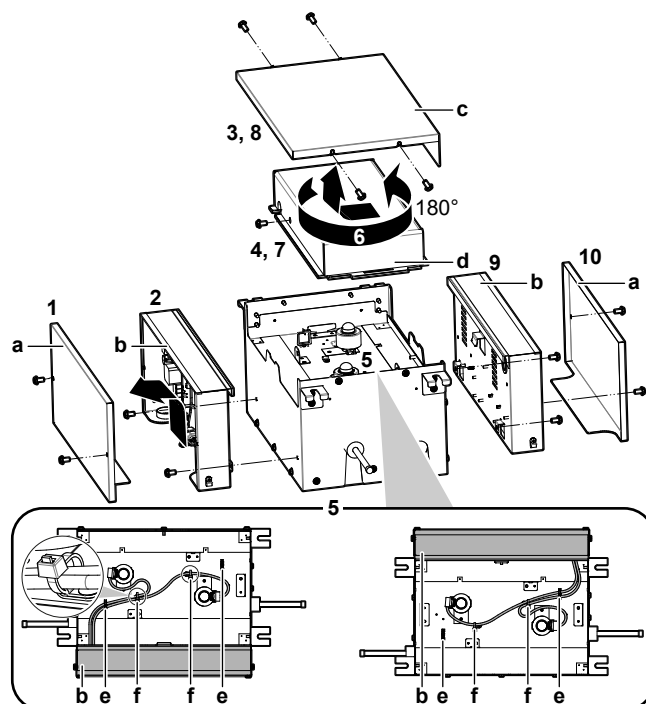

a Control box lid  
 b Control box  
 c Top panel  
 d Coil cover  
 e Wire clip  
 f Tie wrap

- 1 Remove the control box lid (2 screws).
- 2 Remove the control box (2 screws).
- 3 Remove the top panel (4 screws).
- 4 Remove the coil cover (1 screw).
- 5 Change the pull out direction of the wire (motorised valve coil) between the unit body and the control box.
- 6 Rotate the coil cover and top panel 180°.
- 7 Reinstall the coil cover (1 screw).
- 8 Reinstall the top panel (4 screws)
- 9 Reinstall the control box in the new position (2 screws).
- 10 Reinstall the control box cover in the new position.

#### Mount the indoor unit on the suspension bolts

- 1 Attach the hooks to the suspension bolts. Be sure to use:
  - 3 nuts (M8/M10) in 4 locations
  - 2 washers (for M8: outside diameter 24~28 mm, for M10: outside diameter 30~34 mm) in 4 locations.

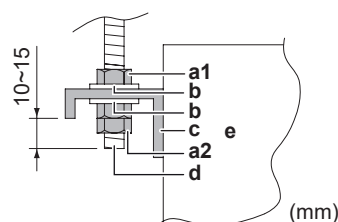

a1 Nut (field supply)  
 a2 Double nut (field supply)  
 b Washer (field supply)  
 c Hanger bracket  
 d Suspension bolt (field supply)

## 6 Piping installation

e Unit

## 6 Piping installation

### 6.1 Preparing refrigerant piping

#### 6.1.1 Refrigerant piping requirements



#### NOTICE

Refrigerant R744 requires strict cautions for keeping the system clean and dry. Foreign materials (including mineral oils or moisture) should be prevented from getting mixed into the system.



#### NOTICE

The piping and other pressure-containing parts shall be suitable for refrigerant and oil. Use K65 (or equivalent) copper-iron alloy tube system for high-pressure applications with a working pressure of 120 bar gauge at the air conditioner side and 90 bar gauge at the refrigeration side.



#### NOTICE

NEVER use standard hoses and manometers. Use ONLY equipment that is designed to use with R744.

- Foreign materials inside pipes (including oils for fabrication) must be  $\leq 30$  mg/10 m.



#### NOTICE

If the ability to close the stop valves for field piping is wanted, the installer MUST install a pressure relief valve on the following piping:

- Outdoor unit to refrigeration indoor units: on liquid piping
- Outdoor unit to air conditioning indoor units: on liquid piping AND gas piping

#### Refrigerant piping diameter

Pipe outer diameter (mm)
$2 \times \varnothing 9.5$

#### Refrigerant piping material

- Piping material:** K65 copper-iron alloy (CuFe2P), maximum operating pressure = 120 bar
- Piping temper grade and thickness:**

Outer diameter ( $\varnothing$ )	Temper grade	Thickness (t) <sup>(a)</sup>	
9.5 mm (3/8")	R420 (drawn)	$\geq 0.65$ mm	

<sup>(a)</sup> Depending on the applicable legislation and the maximum working pressure of the unit (see "PS High" on the unit name plate), larger piping thickness might be required.

#### 6.1.2 Refrigerant piping insulation

- Use polyethylene foam as insulation material:
  - with a heat transfer rate between 0.041 and 0.052 W/mK (0.035 and 0.045 kcal/mh°C)
  - with a heat resistance of at least 120°C
- Insulation thickness:

Pipe outer diameter ( $\varnothing_p$ )	Insulation inner diameter ( $\varnothing_i$ )	Insulation thickness (t)
9.5 mm (3/8")	10~14 mm	$\geq 10$ mm

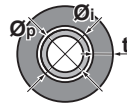

If the temperature is higher than 30°C and the humidity is higher than RH 80%, the thickness of the insulation materials should be at least 20 mm to prevent condensation on the surface of the insulation.

### 6.2 Connecting the refrigerant piping



#### DANGER: RISK OF BURNING/SCALDING

#### 6.2.1 To connect the refrigerant piping to the indoor unit



#### CAUTION

Install the refrigerant piping or components in a position where they are unlikely to be exposed to any substance which may corrode components containing refrigerant, unless the components are constructed of materials that are inherently resistant to corrosion or are suitably protected against corrosion.

- Pipe length.** Keep refrigerant piping as short as possible
- Connection example** to the indoor unit:

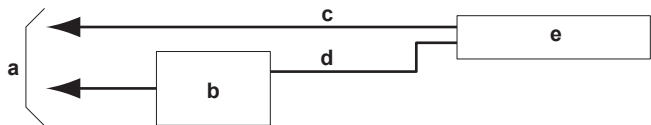

- a Outdoor unit
- b BEV2 unit
- c Gas piping
- d Liquid piping
- e Indoor unit



#### INFORMATION

- Only 1 indoor unit may be connected to each BEV2 unit.
- This chapter describes only the connection procedure to the BEV2 unit. For the connection procedure of the indoor or outdoor unit, refer to the installation manual of the indoor or outdoor unit.



#### WARNING

- Use K65 piping for high-pressure applications with a working gauge pressure of 120 bar or 90 bar, depending on its location in the system.
- Use K65 unions and fittings approved for a working gauge pressure of 120 bar or 90 bar, depending on its location in the system.
- ONLY brazing is allowed for connection of pipes. No other types of connections are allowed.
- Expanding of pipes is NOT allowed.

- Insert the field pipe into the piping on the BEV2 unit side.
- Connect refrigerant piping to the unit using only **brazed connections**.

## NOTICE

When brazing, place a wet cloth on the insulation attached on the unit (a) and make sure the temperature does not exceed 200°C.

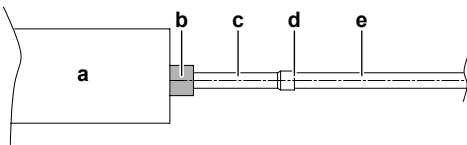

- a BEV2 unit
- b Piping on the BEV2 unit side
- c Insulation attached on the unit
- d Brazed connection
- e Field piping

### 3 Insulate the refrigerant piping on the BEV2 unit as follows:

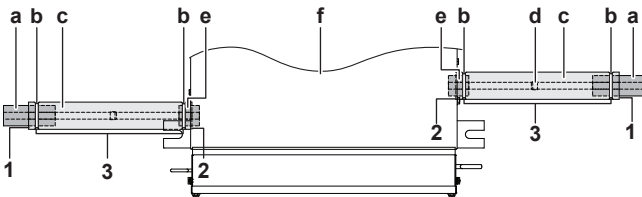

- a Insulation material (field supply)
- b Tie wraps (accessory)
- c Insulation pieces (accessory)
- d Brazed connection
- e Refrigerant pipe connection (attached to the unit)
- f Unit

- 1 Turn up the seams of the insulation pieces.
- 2 Attach to the base of the unit.
- 3 Tighten the tie wrap on the insulation pieces.

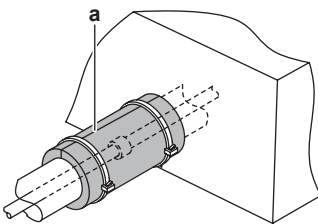

- a Seam of the insulation piece (accessory) facing up

## NOTICE

Make sure to insulate all refrigerant piping. Any exposed piping might cause condensation.

## 7 Electrical installation

### DANGER: RISK OF ELECTROCUTION

### WARNING

- All wiring **MUST** be performed by an authorised electrician and **MUST** comply with the national wiring regulation.
- Make electrical connections to the fixed wiring.
- All components procured on-site and all electrical construction **MUST** comply with the applicable legislation.

### WARNING

ALWAYS use multicore cable for power supply cables.

### WARNING

Use an all-pole disconnection type breaker with at least 3 mm between the contact point gaps that provides full disconnection under overvoltage category III.

### WARNING

If the supply cord is damaged, it **MUST** be replaced by the manufacturer, its service agent or similarly qualified persons in order to avoid a hazard.

### WARNING

Keep the interconnection wiring away from copper pipes without thermal insulation as such pipes will be very hot.

### NOTICE

This is a class A product. In a domestic environment this product may cause radio interference in which case the user may be required to take adequate measures.

## 7.1 To connect the electrical wiring to the BEV2 unit

### NOTICE

- Follow the wiring diagram (delivered with the unit, located at the inside of the service cover).
- For instructions on how to connect the optional equipment, see the installation manual delivered with the optional equipment.
- Make sure the electrical wiring does **NOT** obstruct proper reattachment of the service cover.

It is important to keep the power supply and the transmission wiring separated from each other. In order to avoid any electrical interference the distance between both wirings should **ALWAYS** be at least 50 mm.

### NOTICE

Be sure to keep the power line and transmission line apart from each other. Transmission wiring and power supply wiring may cross, but may **NOT** run parallel.

1 Remove the service cover.

2 Connect the **transmission cable**:

- Take the transmission cable from the accessories of the indoor unit and route the cable through the frames of both units.
- Remove the jumper from connector X70A on the indoor unit PCB and connect the transmission cable to connector X70A.
- Connect the cable to connector X2A on the BEV unit PCB.
- Fix the cable with a small tie wrap (accessory).

3 Connect the **power supply cable**:

- Take the power supply cable from the accessories of the indoor unit and route the cable through the frames of both units.
- Connect the end of the cable with the faston connectors to the indoor unit terminal.
- Connect the other side of the power supply cable to the terminal of the BEV2 unit.
- Fix the cable with a small tie wrap (accessory)

4 Reattach the service cover.

## 8 Commissioning

### Connection to the indoor unit

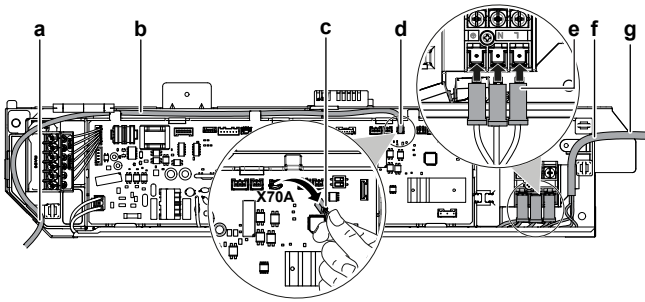

- a Transmission cable feed-through hole
- b Transmission cable (indoor unit accessory)
- c Jumper
- d X70A connector
- e Faston connector
- f Power supply feed-through hole
- g Power supply cable

### Connection to the BEV2 unit

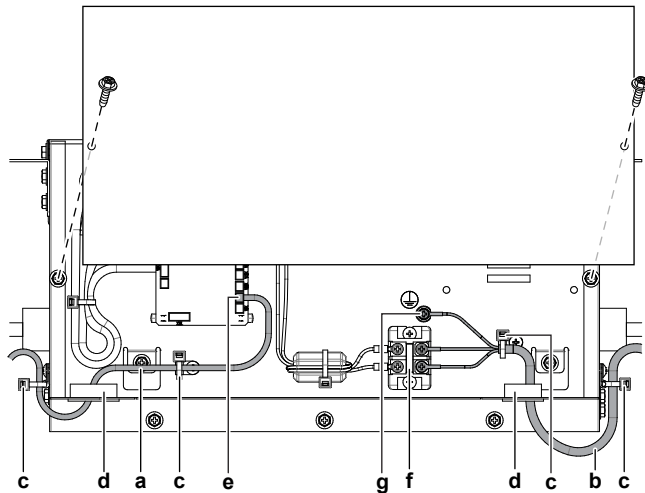

- a Transmission cable
- b Power supply cable
- c Tie wrap (accessory)
- d Wiring feed-through hole
- e X2A connector
- f Power supply terminal
- g Earth

### Wiring example

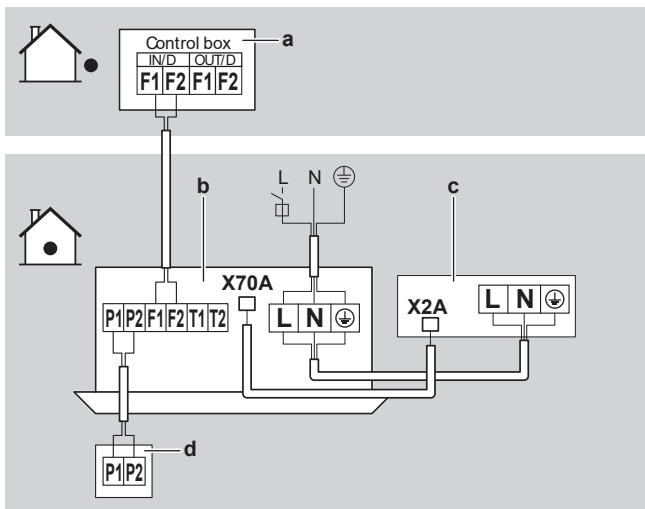

- a Outdoor unit control box
- b Indoor unit
- c BEV2 unit
- d User interface

## 8 Commissioning



### WARNING

Make sure that the service cover is closed after completing the installation of the indoor unit, BEV2 unit, and outdoor unit.



### INFORMATION

Refer to the installation manuals provided with the indoor and outdoor units for the commissioning of the system.

### 8.1 Checklist before commissioning

- 1 After the installation of the unit, check the items listed below.
- 2 Close the unit.
- 3 Power up the unit.

<input type="checkbox"/>	You read the complete installation instructions, as described in the <b>installer reference guide</b> .
<input type="checkbox"/>	<b>Installation</b> Check that the unit is properly installed, to avoid abnormal noises and vibrations when starting up the unit.
<input type="checkbox"/>	The <b>indoor unit</b> is properly mounted.
<input type="checkbox"/>	The <b>outdoor unit</b> is properly mounted.
<input type="checkbox"/>	The <b>refrigerant pipes</b> (gas and liquid) are installed correctly and thermally insulated.
<input type="checkbox"/>	There are <b>NO refrigerant leaks</b> .
<input type="checkbox"/>	There are <b>NO missing phases</b> or <b>reversed phases</b> .
<input type="checkbox"/>	The system is properly <b>earthed</b> and the earth terminals are tightened.
<input type="checkbox"/>	The <b>fuses</b> or locally installed protection devices are installed according to this document, and have <b>NOT</b> been bypassed.
<input type="checkbox"/>	The <b>power supply voltage</b> matches the voltage on the identification label of the unit.
<input type="checkbox"/>	There are <b>NO loose connections</b> or damaged electrical components in the switch box.
<input type="checkbox"/>	There are <b>NO damaged components</b> or <b>squeezed pipes</b> on the inside of the indoor and outdoor units.
<input type="checkbox"/>	The <b>stop valves</b> (gas and liquid) on the outdoor unit are fully open.

## 9 Disposal



### NOTICE

Do **NOT** try to dismantle the system yourself: dismantling of the system, treatment of the refrigerant, oil and other parts **MUST** comply with applicable legislation. Units **MUST** be treated at a specialised treatment facility for reuse, recycling and recovery.

## 10 Technical data

- A **subset** of the latest technical data is available on the regional Daikin website (publicly accessible).
- The **full set** of the latest technical data is available on the Daikin Business Portal (authentication required).

## 10.1 Wiring diagram

### 10.1.1 Unified wiring diagram legend

For applied parts and numbering, refer to the wiring diagram on the unit. Part numbering is by Arabic numbers in ascending order for each part and is represented in the overview below by "\*" in the part code.

Symbol	Meaning	Symbol	Meaning
	Circuit breaker		Protective earth
	Connection		Protective earth (screw)
	Connector		Rectifier
	Earth		Relay connector
	Field wiring		Short-circuit connector
	Fuse		Terminal
	Indoor unit		Terminal strip
	Outdoor unit		Wire clamp
	Residual current device		Heater

Symbol	Colour	Symbol	Colour
BLK	Black	ORG	Orange
BLU	Blue	PNK	Pink
BRN	Brown	PRP, PPL	Purple
GRN	Green	RED	Red
GRY	Grey	WHT	White
SKY BLU	Sky blue	YLW	Yellow

Symbol	Meaning
A*P	Printed circuit board
BS*	Pushbutton ON/OFF, operation switch
BZ, H*O	Buzzer
C*	Capacitor
AC*, CN*, E*, HA*, HE*, HL*, HN*, HR*, MR*_A, MR*_B, S*, U, V, W, X*A, K*R_*, NE	Connection, connector
D*, V*D	Diode
DB*	Diode bridge
DS*	DIP switch
E*H	Heater
FU*, F*U, (for characteristics, refer to PCB inside your unit)	Fuse
FG*	Connector (frame ground)
H*	Harness
H*P, LED*, V*L	Pilot lamp, light emitting diode
HAP	Light emitting diode (service monitor green)
HIGH VOLTAGE	High voltage
IES	Intelligent eye sensor
IPM*	Intelligent power module
K*R, KCR, KFR, KHuR, K*M	Magnetic relay
L	Live

Symbol	Meaning
L*	Coil
L*R	Reactor
M*	Stepper motor
M*C	Compressor motor
M*F	Fan motor
M*P	Drain pump motor
M*S	Swing motor
MR*, MRCW*, MRM*, MRN*	Magnetic relay
N	Neutral
n=*, N=*	Number of passes through ferrite core
PAM	Pulse-amplitude modulation
PCB*	Printed circuit board
PM*	Power module
PS	Switching power supply
PTC*	PTC thermistor
Q*	Insulated gate bipolar transistor (IGBT)
Q*C	Circuit breaker
Q*DI, KLM	Earth leak circuit breaker
Q*L	Overload protector
Q*M	Thermo switch
Q*R	Residual current device
R*	Resistor
R*T	Thermistor
RC	Receiver
S*C	Limit switch
S*L	Float switch
S*NG	Refrigerant leak detector
S*NPH	Pressure sensor (high)
S*NPL	Pressure sensor (low)
S*PH, HPS*	Pressure switch (high)
S*PL	Pressure switch (low)
S*T	Thermostat
S*RH	Humidity sensor
S*W, SW*	Operation switch
SA*, F1S	Surge arrester
SR*, WLU	Signal receiver
SS*	Selector switch
SHEET METAL	Terminal strip fixed plate
T*R	Transformer
TC, TRC	Transmitter
V*, R*V	Varistor
V*R	Diode bridge, Insulated-gate bipolar transistor (IGBT) power module
WRC	Wireless remote controller
X*	Terminal
X*M	Terminal strip (block)
Y*E	Electronic expansion valve coil
Y*R, Y*S	Reversing solenoid valve coil
Z*C	Ferrite core
ZF, Z*F	Noise filter

